

QuickShape Visible

FLEXIBLE VISIBLE PULSE SHAPER

QuickShape Visible is a powerful visible and near-IR pulse shaper that has been designed and engineered for flexibility and ease of use.

Shot-to-shot operation at up to **100 kHz** for high signal-to-noise experiments with the latest high-repetition-rate lasers.

CAPABILITIES & FEATURES

- Shot-to-shot scanning
- Easy-to-use software with advanced features
- Phase cycling & rotating frame
- Create exponential, reverse-exponential pulses, Gaussian and double pulses
- GVD and TOD correction
- Generate your own custom pulse shapes
- User-adjustable spectral resolution

APPLICATIONS

- Time-domain 2D Visible
- Frequency-domain 2D Visible
- Transient 2D Visible
- Coherent control
- Transient absorption spectroscopy
- Rapid-scan optical delay line
- High-repetition-rate chopper

We can tailor the spectral resolution & window to your application

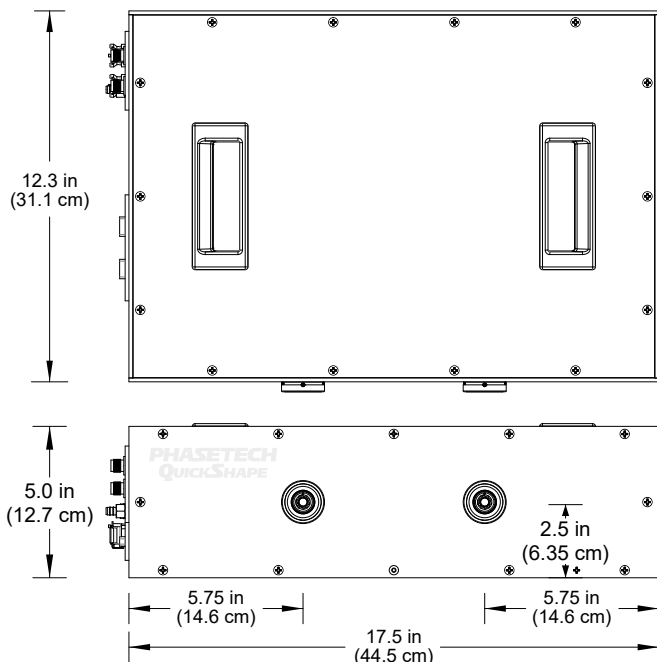

SPECIFICATIONS

Standard AR Coating	450 - 900 nm (other wavelength ranges are available upon request)
Spectral Window	Adjustable (see examples below)
Spectral Resolution	Adjustable (see examples below)
Effective Pixels ¹	> 700
Repetition Rate ²	≤ 100 kHz (higher repetition rate possible for some applications)
Input Polarization	Linear, Horizontal
Input Beam Size (1/e ²)	4.5 mm, collimated
Approximate Size	12.3 x 17.5 x 5 in (31.1 x 44.5 x 12.7 cm)

Example with 1200 g/mm gratings centered at 675 nm

Spectral Window	155 nm
Spectral Resolution	0.20 nm
Max. Double Pulse Delay ⁴	3900 fs

Example with 900 g/mm gratings centered at 790 nm

Spectral Window	215 nm
Spectral Resolution	0.30 nm
Max. Double Pulse Delay ⁴	3800 fs

¹ See our website for more about how the effective pixel size is measured.

² Maximum repetition rate with use of minimum aperture size, repetition rate with full aperture depends on gratings used.

³ Estimated. Depends on gratings and wavelength.

⁴ Calculated based on effective pixel size with gratings specified.

PHASETECH QuickShape Visible

ADDITIONAL INFORMATION

INCLUDES

- Advanced Arbitrary Waveform Generator - load & cycle through over 79,000 pre-defined pulse-shape
- Detailed User Manual
- LabView™ Control VIs
- QuickControl Software Package
- Enclosure
- Control Computer

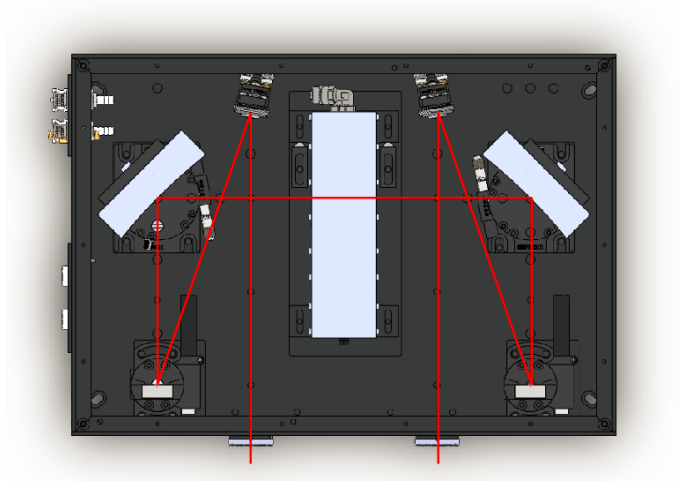

Advanced parabolic mirror design!

Simple layout - easy to align!

Motorized rotation stages for wavelength tuning!

EXAMPLE LAYOUTS

2D Visible

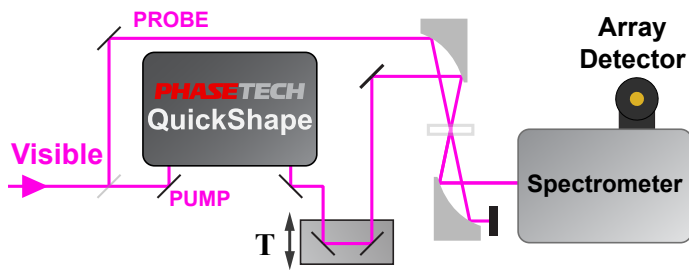

Pump-Probe Spectra

(without a monochromator)

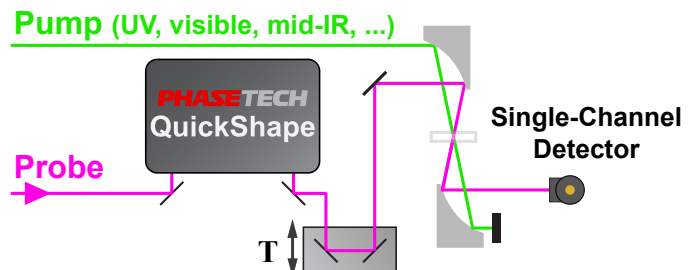

OTHER PRODUCTS

QuickShape IR POWERFUL MID-IR PULSE SHAPER

2DQuick Visible FAST & POWERFUL 2D IR SPECTROMETER

2DQuick IR HIGH-REPEITION RATE 2D VISIBLE SPECTROMETER

see our website for more information on these products

phasetechspectroscopy.com

We follow a policy of continuous product development. Specifications are subject to change without notice. LabView™ is a trademark of National Instruments. Neither PhaseTech Spectroscopy, Inc., nor any software programs or other goods or services offered by PhaseTech Spectroscopy, Inc., are affiliated with, endorsed by, or sponsored by National Instruments.